

NDPD PUMP SUB ZERO PUMPS*

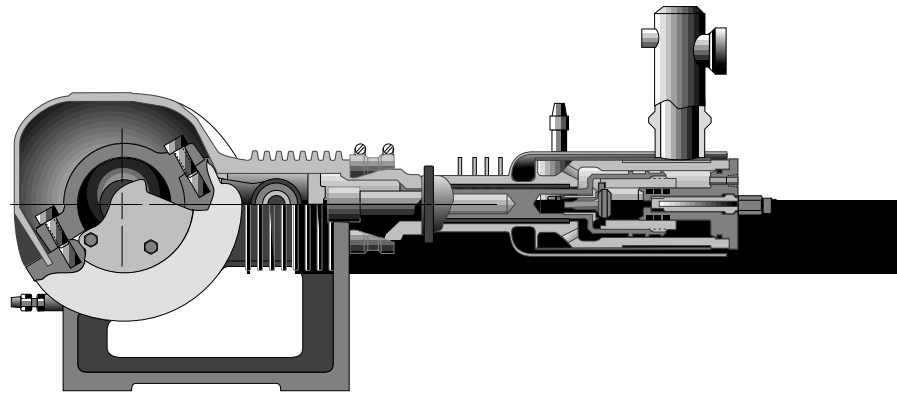

As close to “maintenance free” as you'll get...

PROVIDES...

- TWO STAGE-DOUBLE ACTING PUMPING ACTION
- SMOOTHER, QUIETER, MORE EFFICIENT CAVITATION FREE PUMPING
- LOWER NPSH REQUIREMENTS

Features

- Smoother, quieter operation
- Two stage design provides subcooling & guarantees positive pressure to the main pumping chamber
- Distributed rod loading
- Cavitation free pumping

* U.S. Patent 4239460

WHICH MEANS...

- LONGER PUMP LIFE
- LESS MAINTENANCE
- LOWER OPERATING COSTS

Benefits

- Distributes constant load on cross-head and bearings, giving extended drive-end life
- Cavitation free operation allows for longer life
- Longer life for all cold-end wetted/wearing parts (packing)
- Pumps under difficult conditions which no other pump can match

ACD Representative: